

### Front Suspension

**Anti Roll Bar:**

- 2.2mm Black
- 2.5mm Silver
- 2.8mm Gold
- 3.0mm Black

**Steering System:**

- Stock Rack
- Swing Rack
- Bellcrank Rack



Bumpsteer Washers: \_\_\_\_\_

Camber: \_\_\_\_\_

Caster: \_\_\_\_\_

Toe: \_\_\_\_\_

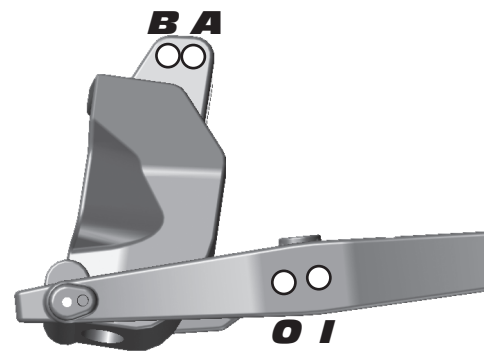

Ride Height: \_\_\_\_\_

**Upper Hinge Pin Bushing**

Front # \_\_\_\_\_  
Up  Down

Rear # \_\_\_\_\_  
Up  Down

**B-Plate Type**

Low  Original

**Kickup Bushing A-Plate**

# \_\_\_\_\_  
Up  Down

### Rear Suspension

**Anti Roll Bar:**

- 2.2mm Black
- 2.5mm Silver
- 2.8mm Gold
- 3.0mm Black

**Wheelbase:**

- Long
- Medium
- Short

Camber: \_\_\_\_\_

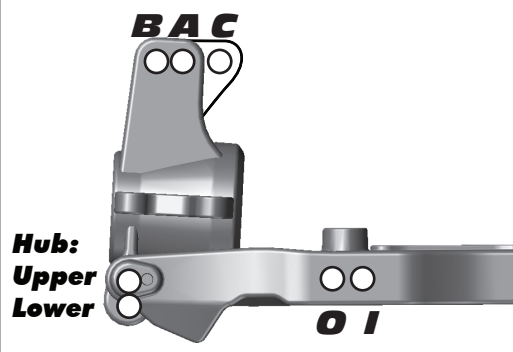

Ride Height: \_\_\_\_\_

**Toe Bushing D-Plate**

# \_\_\_\_\_  
In  Out

**Squat Bushing C-Plate**

# \_\_\_\_\_  
Up  Down

### Front Shocks

Spring: \_\_\_\_\_ Shock Cap: \_\_\_\_\_  
Shock Fluid: \_\_\_\_\_ Length: \_\_\_\_\_  
Piston: \_\_\_\_\_ Rebound: \_\_\_\_\_

### Rear Shocks

Spring: \_\_\_\_\_ Shock Cap: \_\_\_\_\_  
Shock Fluid: \_\_\_\_\_ Length: \_\_\_\_\_  
Piston: \_\_\_\_\_ Rebound: \_\_\_\_\_

### Chassis Braces

- Chassis Braces: \_\_\_\_\_
- Pivot
- Molded
- Aluminum

### Wheel Hex

- Wheel Hex: \_\_\_\_\_
- Narrow
- Wide

### Caster Blocks

- Caster Blocks: \_\_\_\_\_
- Vertical
- Inclined

### Chassis Weight

Weight: \_\_\_\_\_

### Rear Hubs

- Rear Hubs: \_\_\_\_\_
- Standard
- CNC FT Alum.

### Differentials

Front Diff: \_\_\_\_\_  
Center Diff: \_\_\_\_\_  
Rear Diff: \_\_\_\_\_  
Notes: \_\_\_\_\_

### Drivetrain

Dogbone:  \_\_\_\_\_  
CVA:  \_\_\_\_\_

### Gearing

Spur Gear: \_\_\_\_\_  
Pinion: \_\_\_\_\_

### Motor / ESC / Batteries

Motor & Wind: \_\_\_\_\_  
ESC: \_\_\_\_\_  
ESC Setting: \_\_\_\_\_  
Batteries: \_\_\_\_\_

### Tires

Tire (F/R): \_\_\_\_\_ / \_\_\_\_\_  
Compound (F/R): \_\_\_\_\_ / \_\_\_\_\_  
Inserts (F/R): \_\_\_\_\_ / \_\_\_\_\_  
Wheel (F/R): \_\_\_\_\_ / \_\_\_\_\_  
Notes: \_\_\_\_\_

### Radio / Servos

Radio: \_\_\_\_\_  
Steering Servo: \_\_\_\_\_ Steering Expo: \_\_\_\_\_  
Brake Expo: \_\_\_\_\_  
Initial Brake: \_\_\_\_\_ Drag Brake: \_\_\_\_\_  
Dual Rate: \_\_\_\_\_

### Race and Vehicle Comments

Qualify: \_\_\_\_\_ Main: \_\_\_\_\_ Finish: \_\_\_\_\_ TQ: \_\_\_\_\_  
Comments: \_\_\_\_\_  
\_\_\_\_\_  
\_\_\_\_\_

### Track Info

Traction: High  Medium  Low   
Surface: Smooth  Bumpy  Blue Groove   
Soft Dirt  Grass  Clay  Wet   
Astroturf  Dusty  Other: \_\_\_\_\_